

# THE INTERNATIONAL FLYING DUTCHMAN CLASS RULES

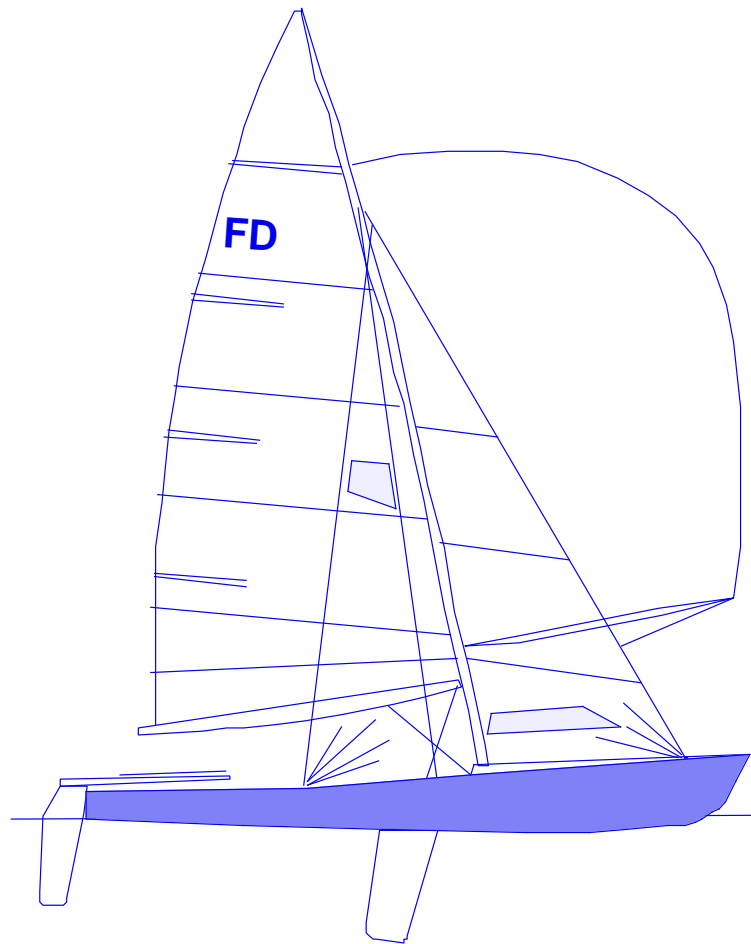

**MARCH 2004**



## THE INTERNATIONAL FLYING DUTCHMAN

### CLASS RULES

Version FD-ISAF M A4    Valid from 1 March 2004

	Rule Number		Rule Number
General	1-5	Centreboard	50
Builders	6	Rudder	51
International Class Fee / Sail Buttons	7	Spars and Rigging	57-67
ISAF plaque	7-12.3	Mast	57-64
Measurement Certificate & Form	8	Boom	65-66
Owner's Responsibility/Subscription Sticker	9	Spinnaker pole	67
Sail Numbers	10	Bands	68-70
Measurers and Measurement Instructions	11	Fittings & Equipment	76-78
Measurement Procedure	12	Sails	80-110
Hull	20-43	Jib/Genoa	37-38, 92
Construction and Shape	20-21	Mainsail	93-98
Length overall	22	Battens	99-100
Sections	23	Spinnaker	102-108
Sheer	24	Crew	111
Stem	25	Expensive Materials	112
Transom	26-28	Equipment Limitations	113
Keel line measurements	29	Wet Clothing	114
Keelbands	30	Outrigger	115
Centreboard slot	31	Foot straps	116
Deck	33	Shoes	117
Section 9 Depth	34	Side Deck Pads	118
Cockpit	35	Advertising	119
Rubbing Strake	36	Sailing Instruction	120
Jib/Genoa size	37-38	Propulsion	121
Weight	39-43	Appendix: Diagrams	
Buoyancy	44-47	Table of Offsets	
Trapeze	48-49		

## General

### 1.0 ISAF Equipment and Racing Rules of Sailing

These class rules are **open class rules** and shall be read in conjunction with the ISAF Equipment Rules of Sailing (ERS) and the Racing Rules of Sailing (RRS). The Measurement instructions, diagrams and the measurement plan form part of these rules. The object of these rules is to ensure that the boats of this class at all times conform, within the tolerances, in shape and weight of **hull, centreboard, rudder** and **mast**, and shape of sail-plan.

Except where used in headings, when a term is printed in “**bold**” the definition in the ERS applies and when a term is printed in “**bold italic**” the definition in the RRS applies. Measurement instructions, within these rules, are in “*italic*” type.

### 1.1 Certification Authority

In alteration to ERS C.5.1 the **Certification authority** is the IFDCO, together with the ISAF.

### 1.2 World and Continental Championships

The IFDCO Championship Rules as set out in the IFDCO byelaws, Appendix I paragraph 9.4.1 states: The measurement committee will be appointed by the **Organizing authority** from names to be submitted to the IFDCO Championship Organizing Committee for approval. The IFDCO chief measurer shall be President of the measurement committee (Principal Event measurer).

### 1.3 Interpretation of the Class Rules - General

Interpretations of the class rules shall be made in accordance with the ISAF Regulations except as provided by 1.4

### 1.4 Interpretation of the Class Rules – At an event

In alteration to ERS H.1.4 interpretations of the **class rules** at an event shall be carried out in accordance with the RRS and ERS, by the IFDCO chief measurer acting on behalf of the **certification authority**. The chief measurer must, as soon as practical after the event, inform the ISAF and the **certification authority** of any new interpretation.

### 1.5 Axes of Measurement (ERS section H.2)

The Flying Dutchman lines are specified by offsets in vertical and waterline planes. The DWL intersects the keel line at stations 0 and 10, thus the **Hull Datum Point (HDP)**, which is at the intersection of the plane of the transom and the keel line is 11 mm above the DWL. The planes of the measurement templates, which are determined by points measured along the keel line and **sheerlines**, are therefore only ideally at the station planes.

2. In order to achieve the objective in Rule 1, the General Committee of the IFDCO reserves the right to exclude a **boat** from racing even if it measures within the letter of these rules, if the owner or builder has taken advantage of a loophole in the rules in order to build a **boat** which is different in shape and/or weight of **hull, centreboard, rudder, mast** or sail plan, from the plans of the class.

3. Alterations to the **Class Rules** shall be made in accordance with ISAF regulation 26.10.

4. In the event of disputes over interpretation, these rules take precedence over the plans. The English text will prevail. The words shall, must and will are mandatory. The word should is advisory and not mandatory. The words can and may are permissive.

5. The IFDCO issues plans, measurement instructions, and measurement equipment, but can never be held liable for faults, errors, omissions, and deviations.

## 6. Builders

Yachts of the Flying Dutchman Class **may** be built by any yard that has paid the required annual fee and acquired a license from the ISAF Ltd. On request, and after advice from IFDCO, builders who do not build more than two Flying Dutchman a year shall receive a free license from the ISAF Ltd. Yards and amateurs building shells only do not need a license. **7. International Class Fee** (Royalty, Building Fee) Payable by Licensed Builders.

**7.1.** The International Class Fee will be **set** by **the ISAF in conjunction with** IFDCO. Payment has to be directed to **the ISAF Ltd.** As receipt for the International Class Fee payment, a numbered **ISAF Plaque** will be sent by the ISAF and **must** be glued to the **boat** before **Fundamental measurement**:

- a. To the starboard forward bulkhead (just forward of the **mast**), or if this is not possible:
- b. To the starboard aft side of the aft bulkhead of **a half** double bottom, or if this is not possible:
- c. To the starboard side of the hog (vertical inner keel) about 300 mm from the transom, or if this is not possible:
- d. To the aft bulkhead of the cockpit.

## 7.2. Sail Buttons

Each **sail** manufactured after 1 September 1984 shall have permanently fixed near to its **tack** an officially numbered **IFDCO** sail button. No **sail will** be accepted for measurement without an **IFDCO** sail button. Buttons **must** not be transferred from one **sail** to another. The sail makers **must** obtain buttons from the IFDCO.

## 8. Certificate and Measurement Form

**Measurement certificates** are issued by the IFDCO after measurement by an **IFDCO approved** measurer, and receipt of the completed measurement forms.

**Measurement Forms:** A **certificate and sail number** will be issued only upon the receipt **by the IFDCO registration of 2 of the** original **3** measurement forms, **each** signed by the builder and an **IFDCO** measurer, which show **that the boat fully complies** with all the rules. When the **boat** is measured outside the country of origin, it is desirable to have the signature of the builder, but not obligatory. When the **boat** proves to be within the rules, the **2** forms are to be signed by the **IFDCO registration**. One form is to be kept by the IFDCO Registration (**white**); one will go to the National Yachting Authority (**green**); or the National FD Class Association. **The third copy (blue) may be kept by the measurer.** A certified photocopy of the measurement form will be part of the **certificate**. The **certificate together** with the certified photocopy of the measurement form **must** be produced upon demand at official FD regattas.

## 9. Owner's Responsibility

No **boat** shall take part in Class Races unless it has:

- a. A valid **certificate** and **certified copy of the** measurement form with Sail **number, and** ISAF plaque number shown;
- b. Registration in the owner's name;
- c. A numbered ISAF plaque glued to the **boat** at the required place;
- d. The **helmsman/crew** have IFDCO **membership and associate membership cards**, with valid year stickers;
- e. A **numbered IFDCO** sail button on each **sail**;

### 9.1 Annual Subscription Sticker

A subscription sticker shall be sent by the National FD Secretary to every member who has paid his annual subscription, as a receipt. The National FD Secretary shall issue a membership card to each new member. The annual sticker shall be applied to this card as proof that the current subscription has been paid.

**9.2.** It is the owner's responsibility that a **boat** racing is fully certified and conforms to these rules and the spirit of the class in all respects, and that after alterations or modifications, the **boat** is re-measured where applicable.

**Warning:** *In connection with this rule, which extends to major regattas also, owners are strongly advised to clear with the IFDCO Committee any point that may contravene the spirit of the rules.*

**9.3.** The **certificate** of a second-hand **boat** is invalid until it has been put in the name of the new owner and countersigned by the **IFDCO registration, which will issue a new sail number in the event of a country change.**

## 10 Sail Numbers

**10.1. Sail numbers**, preceded by the National Letters, shall be issued per country consecutively starting from 1.

### 10.2. Personal Sail Numbers

In accordance with ISAF RR Appendix G1.1(c), National Class Associations may issue personal sail numbers (Sail numbers staying with the owner for every **boat** he owns as long as he sails FD) this number must be shown on the personal IFDCO Membership Card. After the sale of the **boat**, the new owner **must** use the original sail number or his own personal number on his **sails**.

### 10.3. Hull numbers

The sail number of the **boat** must be shown on the transom. **The height of the letters must not be less than a minimum of 30 mm**

## 11 Measurers and Measurement Instructions

**11.1.** Measurers **must** be approved by the IFDCO in close co-operation **with their National Yachting Authority (MNA)**.

**11.2.** A measurer shall not measure his own **boat**, a **boat** built by him or when he is in some way an interested party.

**11.3.** Only the owner and **crew** of the **boat**, the measurer, measurer's assistants, members of the Jury and the IFDCO Technical Committee may be present during measurement at a major regatta.

**11.4. Hulls must** be complete in every respect, **and must have an ISAF plaque (Rule 7.1)** when presented for **fundamental** measurement. **Sails, masts** and other required gear may be measured separately.

**11.5.** Partly built **boats** can be partly measured but the measurer **must** put under his signature - Partly measured - and **must** list on the measurement form the unmeasured items. **The measurement form of such boats must** also bear the name of the measurer who completed the measurement.

**11.6.** If measurers find deviations which do not contravene the exact letter of the rules but which might contravene the spirit of the rules, they **must**, before signing the measurement form, submit the matter to the IFDCO Executive Committee.

**11.7.** Only the IFDCO Executive committee can decide to give a waiver for a rule on which a **boat** deviates. The deviation and waiver are to be noted and countersigned by the IFDCO Chief measurer on the **certificate** and all 3 originals of the measurement form, before the **certificate** can be issued and become valid.

## 12 Hull Measurement Procedure

**12.1. Boats** shall be measured with official certified templates only.

**12.2.** The official templates will be issued by the IFDCO and the ISAF, and consist of 6 Hull shape templates with tie bars, 1 Stem template, 1 Transom angle-height template and 1 Gunwale template. Each template **must have the serial number of the set**, must have been certified as correct and identified as such by a special mark made by the person appointed by IFDCO to check the templates.

*(numbers 13-19 are not used)*

### Hull

**20.** Deviations from the tolerances due to fair wear and damage, which do not affect the performance of the **boat**, shall not invalidate a **certificate** for a particular race, but shall be repaired, and put right as soon as possible.

**21.** Within the tolerances allowed, the **hull** shape must conform to the Mylar plan of the sections, stem and transom at full size and the master plan of lines and verticals to be controlled by the table of offsets. The skin curvature radius **must not be less than a minimum of 75 mm**, except within 100 mm from the keelband. Hollows exceeding 1 mm in depth in the keel or in the **hull** surface aft of section 7, are not allowed. **(For offsets and diagram see appendix)**

**22.** Overall **hull length**, measured along the deck line, is to be 6057 mm plus/minus 12.5 mm.

**23.** Body sections: transom, 1, 3, 5, 7 and 9 **must** be verified with official numbered templates applied in **the** manner shown in the measurement plan.

Tolerances: For the sections: transom, 1, 3, 5 and 7, **the** negative deviation **must not exceed a maximum of 12.5 mm** per section. For section 9, **the** positive deviation **must not exceed a maximum of 12.5 mm**. **Boats** built after 1 November 1981 have to conform to this rule.

**Instruction:** See Measurement Plan. For sections transom, 1, 3, 5 and 7, the gap between template and **hull** **must be between a maximum of 25 mm and a minimum of 12.5 mm**. For section 9, the gap **must be between a maximum of 12.5 mm and a minimum of 0 mm** (i.e., templates touching the **hull**).

**24 Sheer height:** The tolerance is plus 12 mm and minus 6 mm.

**Instruction: Measuring method**

- a. After **measuring** the length, the **hull** is turned upside down and **supported** on trestles. The positions of the stations at the keel and the gunwale are to be determined by taking the following measurements from the outside of the transom along the keel and along the skin at the gunwale.

<b>Station</b>	<b><u>1</u></b>	<b><u>2</u></b>	<b><u>3</u></b>	<b><u>4</u></b>	<b><u>5</u></b>	<b><u>6</u></b>	<b><u>7</u></b>	<b><u>8</u></b>	<b><u>9</u></b>	
For Keel mark	732		1283		1835		2385		2936	3486
4036		4587	5137							
For Gunwale mark	745			1856			2958		4065	
	5210									

- b. Check at the same time the position and width of the centreboard slot (Rule 31). The station templates are set up on the keel and gunwale positions as found above (3 points per station). The adjustable lugs near the gunwale must be adjusted to have equal gaps on both sides between shell and template with the template centre at the centre of the keelband, or with equal sheer heights, whichever gives better results. **One of the studs near the keel must touch the shell, with a tolerance of 2 mm for the other stud.**
- c. Measuring the gap now between shell and template, the variation in width of this gap **must not exceed a maximum of 12.5 mm.** (See details on measurement plan.)
- d. Check with a straight-edge (approx. 1000 mm long) for hollows aft of section 7. Small bumps or cutouts are also prohibited under this rule.
- e. The sheer height **must** be measured where the shell meets the top of the decking by taking the distance to the tie bar of the template. The difference **must not vary more than a maximum of plus 6 mm or minus 12 mm** from the distance of the sheer height mark on the template to the tie bar, with the exception of the stem template (See Rule 25).

**25. Stem, Profile and Height**

The gap between the hull and template, when positioned as per instruction 29a, **must not exceed a maximum of 3 mm plus/minus for shape and 6 mm plus/minus for height.** A bulbous stem is not permitted.

**26. Transom**

The height of the transom on the centreline, excluding the keelband, shall be 290 mm plus/minus 6 mm. A hard chine transom is not permitted.

**27.** The transom **must** be placed at the extreme end of the **hull** and **must** be vertical to the waterline. **The spacing between the transom template lug and the baseline controls this, and it must be between 5 mm and 15 mm.**

**28.** No projections or apertures are permitted in the transom within 20 mm of the outside of the hull other than rudder pintles and 2 drain holes, each not larger than a **maximum of** 20 mm diameter. Corks or normal drain hole fittings protruding aft of the transom are allowed.

### **29. Keel line measurements**

The shape of the keel line shall be checked by measuring the **minimum** distance to the baseline, which is the line drawn from a point 100 mm under the keel at the transom to a point 120 mm under the keel at station 9. These **minimum** distances, H measurements, **must** be taken **at each station**:

<b>Station</b>	<b><u>1</u></b>	<b><u>2</u></b>	<b><u>3</u></b>	<b><u>4</u></b>	<b><u>5</u></b>	<b><u>6</u></b>	<b><u>7</u></b>	<b><u>8</u></b>
"H"	72	56	45	49	40	46	59	80

Tolerance: The absolute value of the algebraic difference of the greatest positive and greatest negative deviations **must** not exceed 12.5 mm.

#### ***Instruction: Measuring Method***

- a. *Put the stem-template with its lugs on the stem itself, not on the stem band, and the aft end of the template as much forward or aft of station 9 as the **hull** is respectively longer or shorter than 6057 mm overall (measured under rule 22). The gap between the template and the stem is nowhere to **exceed a maximum of** 6 mm. For measuring the height of the stem, the lugs **must** be placed on the stem itself, not on the stem band. (If the stem band is not visible 3 mm shall be accepted as such). The top of the stem **must** be between the height marks on the template.*
- b. *Put the transom height-angle template on the bottom of the **hull** next to the keelband. The top of the transom **must** then be between the maximum and minimum height marks on the template. Then put the template on the keel (not on the keelband) together with the stem template also on the keel. Using the triangular-shaped holes in the templates, draw a string tight between the templates. This is the baseline. The gap between the lug on the arm of the transom angle template and the string **must** be between 5 and 15 mm (see Measurement Plan for directions).*
- c. *Now take the H measurements between the baseline and the keel.*
- d. *When the thickness of the keelband is consistent, the stem and transom template **may** be put on the keelband and the H measurements **must** then be taken between the base line and the keelband.*

### **30. Keelbands**

Keelbands of metal, hardwood, plastic or glass-reinforced plastic **must** be fitted and **must** measure between 3 and 10 mm in thickness and between 6 and 15 mm in width.

The keelband **must** run the full length of the **hull** along the keel including the stem. If the keelband is faired into the **hull** so that its width and thickness cannot be determined, the junction between the **hull** and the keelband **must** be assumed to be where the **hull** is 6 mm wide. In the way of centreboard slot, the keelband **must** be duplicated and **must** overlap the centre keelband by not more than **a maximum of 50 mm** at each end. Keelband joining fishplates are permitted.

### 31. Centreboard slot

The aft end of the centreboard slot must be between 2000 and 2106 mm and the forward end must be between 3396 and 3408 mm from the transom station.

The width of the slot **must** not exceed **a maximum of 40 mm**.

*(number 32 is not used)*

### 33. Deck

The deck at the mast partners **must** not be higher than the deck line. The deck line is the imaginary line between the top of the transom at the centreline and the highest point of the stem (excluding stem fittings).

**Instruction:** *Erect a taut line 150 mm above both the stem and the top of the transom, i.e. parallel to the deckline. The mast partners **must** be at least 150 mm below this line.*

34. The depth of section 9 **must** be 609 mm plus/minus 6 mm.

**Instruction:** *This is checked by applying the station 9 template and measuring the distance between the tie bar and the line used for checking the height of the deck (to be between 90 and 102 mm). (See the diagram on the Measurement Plan.)*

### 35. Cockpit

The area of the **hull**, including spinnaker holes, not covered by fixed decking **must be between a minimum of 1.5 m<sup>2</sup> and a maximum of 4.2 m<sup>2</sup>**. Fixed decking is decking which is screwed, nailed, glued or moulded-in with the **hull**, which **must** not be removable during the race and which lies above or at the same level **as** the sheer height.

**Instruction:** *To find the limits of the cockpit area, a straight edge shall be laid across the cockpit. Measure the distance between the straight-edge and the sheer. The limit of the cockpit is where the inboard side of the side deck is at the same distance from the straight-edge as the sheer. It may be necessary to use Simpson's rule to determine the area. (See Measurement Plan).*

### 36. Rubbing Strakes

All **hulls must** be fitted with rubbing strakes (sheer guards) along the full length of the **hull**, which **must** nowhere measure horizontally more than **a maximum of 50 mm** or less than **a minimum of 5 mm** and vertically more than **a maximum of 35 mm** or less than **a minimum of 10 mm**. The rubbing strake is to be placed along the topsides at the gunwale. The width of rubbing strake across the transom and/or forward of the stem **must not exceed a maximum of 12.5 mm**.

***Instruction:** A gunwale template is to be used to check maximum dimensions. Callipers are to be used to check minimum **dimensions**.*

**37. The bearing point of the jib sheet** on its fairlead must be forward of a **plane perpendicular to the deckline and 2000 mm along the deckline from the transom**. It **must** be impossible to fix the bearing point of the jib sheet on its fairlead, **or** to extend the **operational clew cringle of the jib, aft of this plane**. The bearing point of the jib sheet on its fairlead **must not exceed a maximum of 60 mm** from the upper side of the deck. The bearing point of the jib sheet is the after most point of the bottom of the groove of a sheave, or the forward side of the opening of a fairlead for the jib sheet. **(See diagram)**

**38.** When the **boat** is fully rigged with **sails** hoisted in racing trim and sheeted for windward sailing, no part of the jib **must** project forward of or above an imaginary line, drawn from a point on the deck line 5450 mm from the aft side of the transom to a point on the **mast** below **the lower edge of Limit mark** (band) number 4, with a tolerance forward of 5 mm. **(See diagram)**

### 39. Weight

The **hull weight**, including all fixed and movable fittings buoyancy apparatus as prescribed in Rules 44-47 (whether removable or fixed) and running gear, **must not be less than a minimum of 130.0 kg**.

*(numbers 40 and 41 are not used)*

**42.** If the **hull** as weighed in Rule 39 weighs less than 130.0 kg, lead **corrector weights must** be permanently fastened to the underside of the deck, forward of the **mast**, be easily visible and stamped by the measurer. The actual weight **must** be stated on the measurement form. No **boat** shall carry more than **a maximum of 15.0 kg of corrector weights**.

**43. The corrector weights** may be adjusted to comply with the minimum **hull weight**, Rule 39, only **after** a measurement by an **IFDCO approved** measurer. The amount removed shall be marked on the measurement form **and certified by the measurer**.

#### 44. Buoyancy

The **boat shall float** its own weight when all buoyancy tanks or bags have been removed or filled with water. **Boats** built of non-buoyant material shall have rigid buoyancy made of closed cell foam plastic, or similar buoyant material, which is permanently attached to the hull. Buoyancy tanks or bags shall provide a minimum of 220 kg of positive buoyancy. At least two completely independent buoyancy tanks or bags, of at least 50 kg buoyancy each, are required.

*Instruction:* Volume of buoyancy should be 0.22 m<sup>3</sup> of air or 0.28 m<sup>3</sup> for styrofoam or similar material.

(number 45 is not used)

**46. Buoyancy apparatus** must be kept securely fastened and fully effective at all times.

**47.** The buoyancy must be fitted to the hull such that in the event of complete flooding, the boat will float approximately level with an effective weight of not less than a minimum of 220 kg placed at a point between the mast and a position 1500 mm aft of the mast.

#### 48. Spars and Equipment

ISAF **RRS 49.1** is amended to allow a Trapeze, which consists of 2 wires or lines attached directly or indirectly to the mast, one on each side, which can be fastened to a trapeze harness. The trapeze shall not be used to support more than one person at a time. The weight of the trapeze hooks, handles, rings, and gear to adjust the length between the trapeze wire or line and the trapeze harness, must not exceed a maximum of 1.0 kg. “

**49. The trapeze harness** may be attached directly or indirectly to a trapeze wire or line but only by means of a single quick release system (2 seconds). The weight of the trapeze harness must not exceed a maximum of 4.0 kg and shall float after complete immersion.

#### 50. Centreboard

**50.1** The shape of the under hull part of the centreboard, in its lowest position, must conform to the equivalent part of the full size Mylar plan. With the leading edge fully up against the line of the Mylar plan, within a tolerance of maximum 3 mm for local gaps, the tolerance is plus or minus 6 mm on the bottom and trailing edges and on the curves at the bottom of the centreboard. A stop must be fitted on the centreboard to prevent it from being lowered farther than a maximum of 1060 mm under the hull. The use and position of a centreboard bolt, notch or holes are optional.

**50.2.** The weight of the complete centreboard must not be less than a minimum of 5.50 kg.

**50.3.** Thickness of the under hull part of the centreboard must not exceed a maximum of 23.0 mm.

**50.4.** It **must** be possible to raise the **centreboard** into its case by rotating it so that the leading edge of the **centreboard** is close to and approximately parallel to the keel **line**. When it is fully or partly lowered, no part of the **centreboard** shall be aft of the extension of **that part of** the trailing edge that is below the **hull**. **(See diagram)**

## **51. Rudder**

**51.1** The shape of the part of the **rudder** blade, when in its lowest position, which is situated under the **extended keel line**, **must** conform to the equivalent part of the full size Mylar plan. With the leading edge fully up against the line of the Mylar plan, **with**in a tolerance of **maximum** 3 mm **for** local gaps, **the** tolerance **is** plus or minus 6 mm on the bottom and trailing edges, and on the curves at the bottom of the **rudder**. **(See diagram)**

**51.2.** **The total weight of the complete rudder including fittings, tiller and tiller extension must not be less than a minimum of 4.00 kg.**

**51.3.** The part of the **rudder** projecting under the extended line of the keel **must** not project under this line more than **a maximum of** 810 mm. The leading edge of **this** part of the **rudder** **shall make an angle that must not exceed a maximum of** 105 degrees with the keel line. **When racing boats** with lifting rudder blades **must** fix the position of the leading edge as above by means of a pin, unless a special exception is made in the sailing instructions. The distance from the leading edge of the **rudder**, at the **point of intersection with the extended** keel line, **must not exceed a maximum of** 60 mm from the transom. **(See diagram)**

**51.4.** A safety device **must** be fitted so that the **rudder** cannot come off unintentionally if the **boat** is inverted.

**51.5 Tiller** The tiller may extend aft of the transom **not more than a maximum of** 1000 mm.

**51.6 Double rudders and rudders** fully or partly forward of the plane of the **transom** are prohibited. **Trim tabs**, **lifting foils** or similar contrivances, **attached to the rudder** and/ or transom are **prohibited**.

*(numbers 52-56 are not used)*

## **57. Spars and Rigging. (See diagram)**

**Mast.** Permanently bent **masts** and rotating **masts** are prohibited.

**58. The weight** of the **mast** (excluding trapeze hooks, shroud end fittings) **must not be less than a minimum of** 11.0 kg. Mast **corrector weights** **must** be permanently attached to the **mast**.

The height of the centre of gravity of the **mast** must not be less than a minimum of 2500 mm above the top of **Limit mark** (band) number 1.

***Instruction:** For the mast CG measurement the halyards must be in their sailing position. The shrouds, forestay and trapezes must be stretched along the mast and attached at a point 2500 mm above the top of the **Limit mark** (band) number 1. Those parts of the rigging below this point may be supported. When a knife-edge at 2500 mm above band 1 supports the mast it must tip, **Top point** down.*

**59.** The **mast** must have openings near the **top** and the **heel** to allow the **mast** to drain. The sum of the areas of the openings at the top and at the heel must not be less than a minimum of 150 mm<sup>2</sup>.

**60. Mast Spar Cross-Section.** The distance from the **fore side** to the **aft side** of the **mast** must not exceed a maximum of 100 mm.

**61. Mast Position:** A stop must be fitted at the mast step to prevent the “mast heel measurement point” from being moved aft of a point perpendicularly down from the deck line and 3600 mm from the transom, as measured along the deck line. The mast heel must be on the centreline. Slides or carriages on the mast heel track are prohibited. (See diagram)

**62. Mast Rigging:** Runners, running backstays and rigid forestays are prohibited, and only a single centreline adjustable backstay is allowed. The shrouds must be installed such that movement of their lower ends is impossible while racing. A flexible or solid babystay, if fitted, must not be attached higher than the **Lower point**, i.e. the upper edge of band number 2 (see Rule 68).

**63. A forestay**, of minimum diameter 2 mm, and of material of strength equivalent to stainless steel wire, must be rigged. The position of the forestay must be forward of the **luff** of the jib and approximately on the centre line, see ISAF RR 54. The forestay must be independent of the jib, and must support the **mast** when the jib is lowered, or the jib halyard or **tack** is broken in a strong wind. The measurer must be convinced of a seaman-like job, also under the foredeck.

**64.** It must normally be possible to lower the main and the jib from the cockpit, while the **mast** is standing in its normal sailing position.

**65. Boom.** Permanently bent **booms** are prohibited.

**66.** The **boom**, without fittings, must be able to pass through a circle having a diameter of 150 mm.

**67.** The **Spinnaker Pole** length must not exceed a maximum of 2500 mm. The **spinnaker pole fitting projection** must not exceed a maximum of 50 mm.

**68. Limit marks** must be bands around the spar, of minimum width 10 mm in contrasting colour to the **spars**. The relevant edge must be marked with a scribed line or centre punch mark, as follows:

- No 1: The upper edge of this **limit mark** (band) must be under the deck level at the **mast**.
- No 2: The **Lower point (Mast Datum Point)**, the upper edge of the **Lower limit mark** (band) must be less than a maximum of 800 mm above the upper edge of band No 1.
- No 3: The **Upper point**, the lower edge of the **Upper limit mark** (band) must be less than a maximum of 6400 mm above the upper edge of band No 2.
- No 4: The lower edge of this **limit mark** (band) must be less than a maximum of 5250 mm above the upper edge of band No 1.
- **Boom Outer point**, the inner edge of the **Outer limit mark** (band) must be less than a maximum of 2840 mm from the aft side of the **mast**.

**(See diagram)**

**69. The bearing point of the spinnaker halyard** on its fairlead or sheave **must** be below and aft of the line from a point on the forward edge of the **mast** 500 mm above the lower edge of the No 4 band, to a point 160 mm forward (measured perpendicular to the forward edge of the **mast**) of the lower edge of the No 4 band. **(See diagram)**

**70. The extension of the top of the boom**, when perpendicular to the **mast**, shall not cross the **mast** at a point lower than the **Lower point**, i.e. the upper edge of the band number 2. A stop on the **boom** shall prevent the **clew point** of the **mainsail** from extending beyond the **outer point**. **(See diagram)**

*(numbers 71-75 are not used)*

## **76. Fittings and Equipment**

Hydraulic, pneumatic and electrical devices (including instruments) are prohibited. But electronic **timing devices** and magnetic and electronic compasses are permitted, provided they have no data correlation capabilities.

*(number 77 is not used)*

**78. The following must** always be carried on board:

- 2 paddles, minimum length 1000 mm; each of minimum weight 0.25 kg.
- 2 adequate **personal buoyancy** aids each of which **must** support at least 5.0 kg of lead **when immersed** in water.
- 1 towing line, synthetic material, minimum diameter 8.0 mm, minimum length 15.0 m and dry weight not less than a **minimum of** 0.50 kg.

An anchor plus **anchor** line are required only when and as specified in the Notice of Race and/or in the Sailing Instructions.

*(number 79 is not used)*

## 80. Sails

The dimensions given on the sail plan are maximum, except the measurement giving the position of the top batten (minimum dimension). **Sails must** be of **woven ply** (Mylar or Kevlar **are prohibited**, see Rule 112.).

**81.** All **sails must** be **single woven ply**. The body of the mainsail and the genoa **must** each be of a single colour except for **sail windows**, and markings in accordance with **ISAF RR 77 and Appendix G**. **Reinforcements are permitted without limitation but** it **must** be possible to fold **the sail, including reinforcements**, by hand in any direction within an outside diameter of 8.0 mm.

**82. Double luff sails** are prohibited.

**83.** **Sail openings, except eyelets on the centre line of the spinnaker, and windows, are prohibited.** **Windows, made of any material, are permitted only** in the mainsail and in the genoa/jib with a total area **that must not exceed a maximum of 1.00 m<sup>2</sup>** in each **sail**.

*(number 84 is not used)*

## 85. Emblems - Sail Letters – Numbers

The class emblem shall be the letters **FD**. The sail number, letters and class emblem **must** be placed **in accordance with** the ISAF RR Appendix G. In addition to ISAF Appendix G1.1 (b) mainsails and spinnakers **must** carry national letters in home waters. **Contrary to ISAF RR Appendix G1.3(e) national letters and sail numbers are not required on genoas.**

**86.** After a **sail** has passed measurement, **the measurer shall stamp and sign the sail.**

**Jib/Genoa** *(Note Rules 37 and 38 repeated for convenience)*

**37.** **The bearing point of the jib sheet** on its fairlead must be forward of a **plane perpendicular to the deckline and 2000 mm along the deckline from the transom**. It **must** be impossible to fix the bearing point of the jib sheet on its fairlead, **or** to extend the **operational clew cringle of the jib, aft of this plane**. The bearing point of the jib sheet on its fairlead **must not exceed a maximum of 60 mm** from the upper side of the deck. The bearing point of the jib sheet is the after most point of the bottom of the groove of a sheave, or the forward side of the opening of a fairlead for the jib sheet. **(See diagram)**

**38.** When the **boat** is fully rigged with **sails** hoisted in racing trim and sheeted for windward sailing, no part of the jib **must** project forward of or above an imaginary line, drawn from a point on the deck line 5450 mm from the aft side of the transom to a point on the **mast** below **the lower edge of Limit mark** (band) number 4, with a tolerance forward of 5 mm. **(See diagram)**

*(numbers 87-90 no longer used)*

**91.** Elastic strips and regulating cords in or attached to the **foot** of the jib or genoa are prohibited.

**92.** No headboard, battens or foot club are allowed in the jib.

### **Mainsail**

**93.** Loose-footed mainsails are prohibited.

*(number 94 is not used)*

**95.** The headboard of the mainsail **must** not exceed a maximum of 150 mm in any direction. **(See diagram)**

**96.** The mainsail when set **must** lie between the **upper point** and the **lower point** on the mast and the **outer point** on the **boom**, i.e. between the bands.

**97.** The **leech length** must not exceed a maximum of 6800 mm.

**98.** The **upper width** of the mainsail is the shortest distance from the **upper leech point**, which is 3400 mm from the **head point**, to the **luff**, and must not exceed a maximum of 1900 mm.

**99.** The extension of the upper edge of the inside of the upper **batten pocket** **must** meet the **luff** at a point a minimum of 1500 mm from the **head point** (the **luff** being stretched so as to remove wrinkles in the material of the **sail**). The distance from this point to the **leech**, measured along the inner edge of the upper batten pocket **must not exceed a maximum of** 1010 mm. **(See diagram)**

**100.** A maximum of 4 sail battens are permitted in the mainsail. The **batten pockets** **must** divide the **leech** into equal parts plus or minus 100 mm. The **batten pocket inside widths** **must not exceed a maximum of** 60 mm. The **batten pocket inside lengths** **must not exceed a maximum of** 1000 mm.

*(number 101 no longer used)*

### **Spinnaker**

**102.** Spinnakers **must** be symmetrical in form and construction.

**103.** The **luff lengths** must not exceed a maximum of 5500 mm.

**104.** The **Foot median** must not exceed a maximum of 6600 mm.

**105.** The straight-line distance from the **Clew points** to the **Mid foot point** must not exceed a maximum of 2050 mm. The **Foot Irregularity** must not exceed a maximum of 20 mm.

**106.** The **upper leech points** are at 2750 mm from the **head point**. The spinnaker **upper width** must not exceed a maximum of 3900 mm.

(number 107 no longer used)

**108.** The spinnaker headboard **must not exceed a maximum of 150 mm in any direction.**

(numbers 109-110 no longer used)

### **111. Crew**

The **crew must** consist of two persons.

### **112. Expensive Materials**

Unusually expensive materials or equipment shall be deemed to be contrary to the spirit of the class and may be prohibited. Before using such materials and/or equipment, permission **must** be obtained from the General Committee **of the IFDCO**. Composite materials such as those incorporating boron and other materials of limited availability are prohibited. Carbon fibre (fibres of graphite) and/or aromatic polyamides (aramids) such as Kevlar (Dupont trade name) **are prohibited in masts (including spreaders) and sails.**

### **113. Equipment Limitation**

a) In regatta series, certain limitations regarding equipment may be enforced when the notice of race and the sailing instruction contain the following provisions:

"This regatta series named \_\_\_\_\_ from \_\_\_\_\_ to \_\_\_\_\_ has limitations as to equipment in accordance with Rule 113."

b) Definition of regatta series: A regatta series is a number of races scheduled to be sailed on consecutive days (one or two days or rest days or non-sailing days do not break the sequence) or on two consecutive weekends or long weekends, for one points prize or title.

c) The limitations regarding equipment for a series are:

1 mainsail, 1 spinnaker, 2 genoas, 1 **mast**, 1 **boom**, 2 **spinnaker poles** , 1 **centreboard**, 1 **rudder**.

d) If there is any damage to the equipment as mentioned under subparagraph c), it is at the discretion of the jury to allow replacements.

e) Marking limited equipment: The equipment mentioned in c) shall be identified by clearly visible markings, which cannot be transferred to other equipment.

### **114. Wet Clothing**

**Clothing Weights** **are to be determined as specified in ISAF RRS Appendix H and must** be as specified below:

**Crew:** Total weight of clothing and equipment worn or carried, excluding trapeze harness, socks and shoes, **must not exceed a maximum of 10.0 kg**

**Helmsman:** Total weight of clothing and equipment worn **must not exceed a maximum of 7.0 kg**; weighed as for the **crew**.

**115. Outrigger**

In contravention to ISAF RR 50.3, an outrigger, of maximum 60 mm outside the **hull** and not more than **a maximum of** 500 mm from the shrouds, is allowed for leading the spinnaker guy.

**116. Foot straps**

**Foot straps, which support the crew's feet, further outboard than the gunwale rubbing strip are prohibited.**

**117. Shoes**

The soles of the **crew's** footwear (trapeze man) **must** not be thicker than 30 mm.

**118. Side Deck Pads**

Detachable side deck pads, are allowed aft of the bearing point of the jib sheet (Rule 37) but **must** not project outside of the maximum permitted width of the rubbing strake (Rule 36).

**119. Advertising**

Advertising is permitted in accordance with ISAF RR 79 and Appendix 1, Regulation 20, Category C, but restricted, in accordance with regulation 20.4.4, as shown in the diagram in the appendix.

**120. Sailing Instructions**

For World and European Championships, only the latest version of the ISAF Standard Sailing **Instructions, ISAF RR Appendix K, as amended by the IFDCO and ISAF to be in compliance with the FD Championship Rules, must** be used.

**121. Propulsion**

All of ISAF RR 42 is altered (as permitted by ISAF RR 86.1 (c)) to read as follows:  
On a free leg of the course, the following actions are permitted for the sole purpose of accelerating a **boat** down the face of a wave (surfing) or, when planing conditions exist, responding to an increase in the velocity of the wind:

Not more than **a maximum of** three rapidly-repeated trims and releases of any **saill** (pumping). There **must** be no further pumping with respect to that wave or increase of wind. **There must be no more than a maximum of three consecutive rapidly repeated alterations of the helm while racing.**

---

### ***Equipment required for measurement.***

- a. *Copy of current **Class rules** and Mylar measurement plan*
- b. *Triplicate measurement form (White, green. and blue)*
- c. *Stamps for marking the **boat** and gear*
- d. *Self-adhesive paper or other means (pencil, etc.) for marking station points*
- e. *Set of certified official templates*
- f. *3 padded trestles*
- g. *Accurate weighing machine (up to 150 kg, 0.1 kg)*
- h. *Accurate weighing machine (up to 15 kg, 0.1 kg)*
- i. *7 m fine strong thin line*
- j. *10 m steel tape*
- k. *2 or 3 m steel tape*
- l. *Two 150 mm, 0.5 mm steel rules*
- m. *Micrometer*
- n. *Callipers of the inside and outside type*
- o. *Centreboard thickness gauge (23 mm)*
- p. *Feeler gauges, 0.10 and 2.0 mm*
- q. *2 mm feeler*
- r. *1000 mm straight edge*
- s. *1100 mm flexible batten*

**Appendix:****Diagrams**

Length LOA	6.06 m
Length DWL	5.50 m
Beam	1.78 m
Hull Weight	130.0 kg
Sailing Weight	165.0 kg
Mainsail	10.2 m <sup>2</sup>
Genoa	8.4 m <sup>2</sup>
Spinnaker	21 m <sup>2</sup>

## Sailplan of the Flying Dutchman International Class

Drawn by A. Verkooijen Sept 1993

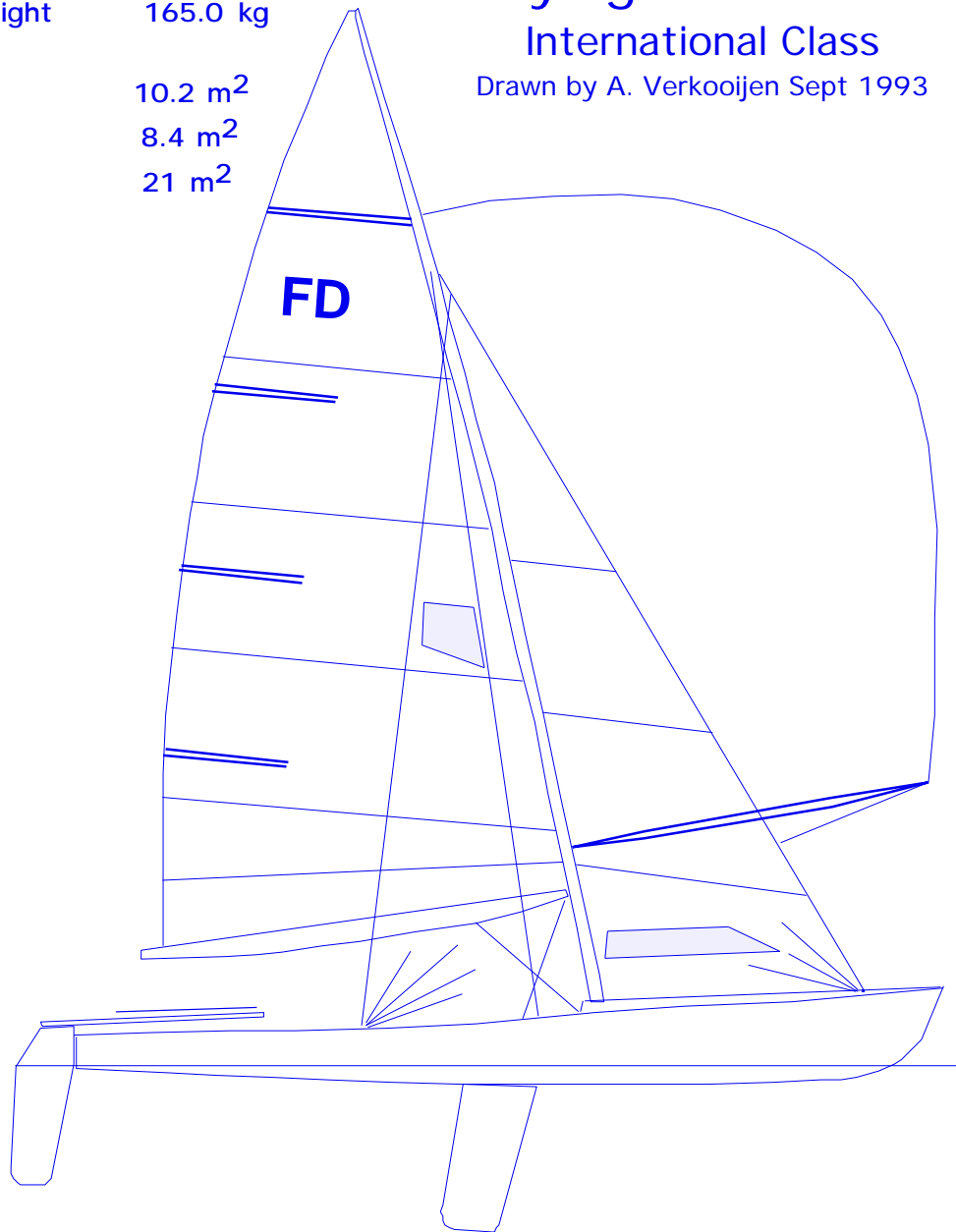

## Genoa Sheet Fairlead Rule 37

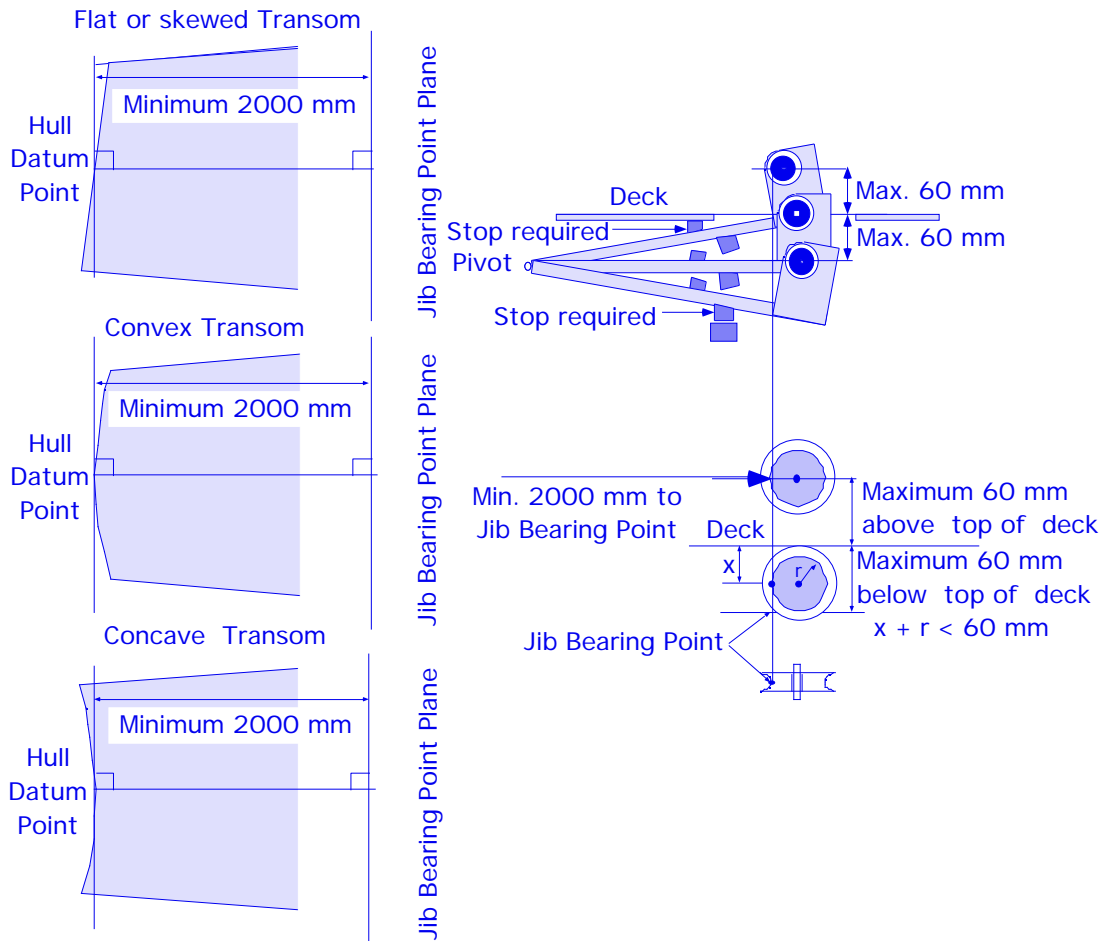

## Centreboard and Rudder Rules 50-51

Centreboard	Max. thickness	23.0 mm
Rule 50	Min. weight	5.50 kg

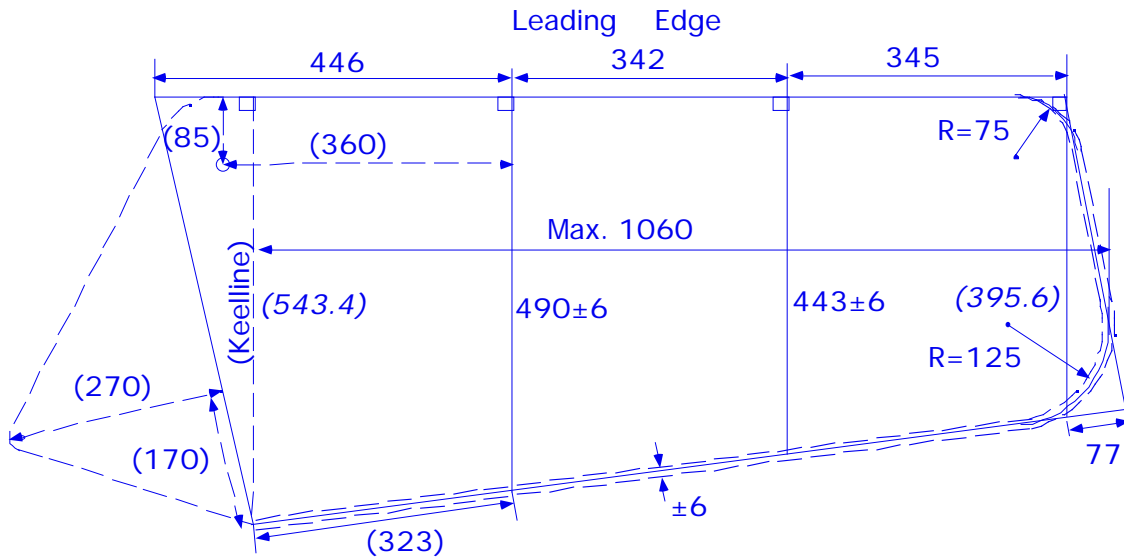

Rudder	Thickness: free
Rule 51	Min. weight: 4.0 kg (including tiller and extension)

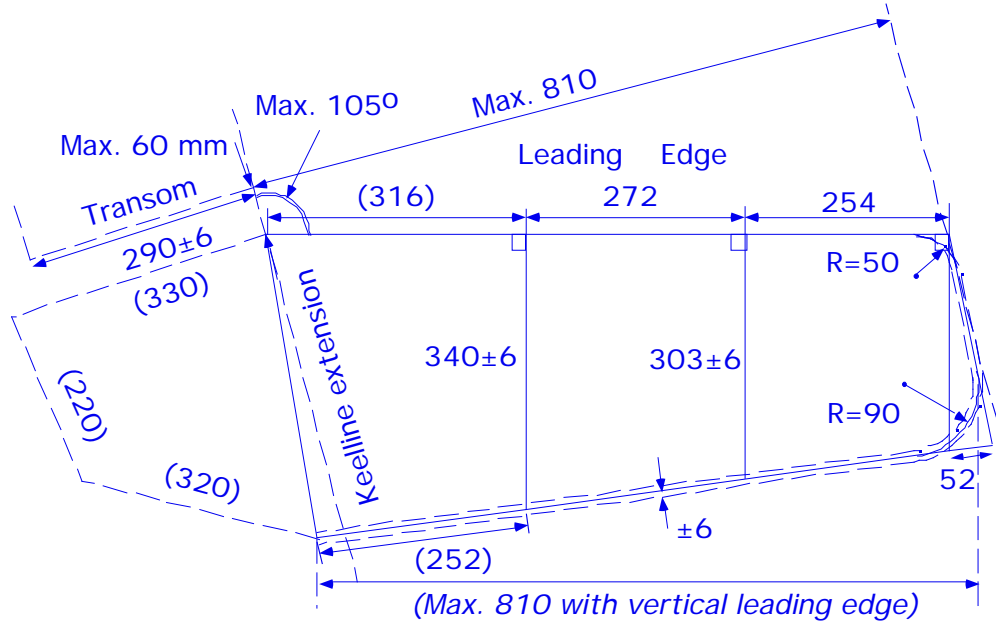

Notes: Only under keel line part must conform  
 Dashed lines are advised shapes and dimensions only  
 Keel line drawn perpendicular to C/B leading edge, at Max. depth.  
 Leading edge of rudder drawn at 105° to keel line, at Max. Depth  
 Dimensions in mm, (suggested in brackets), (*derived in italics*).

# Mast and Boom Rules 57-71

Upper Limit Mark (band) #3  
Upper Point

## Rule 68

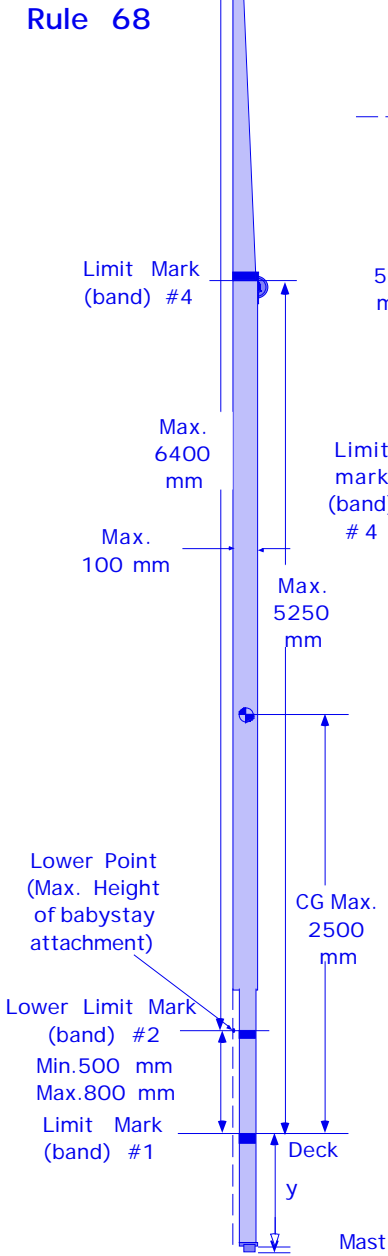

## Rule 69

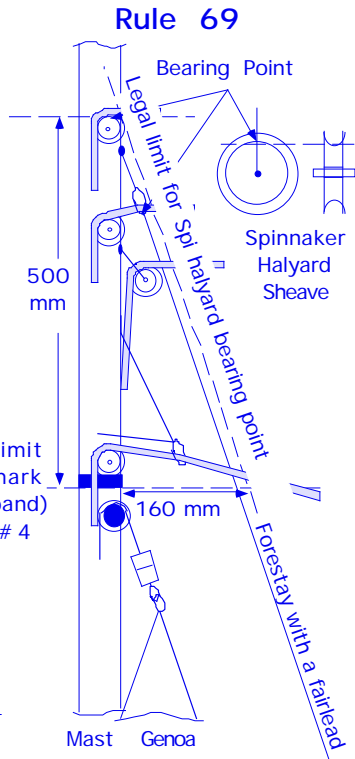

## Rule 38

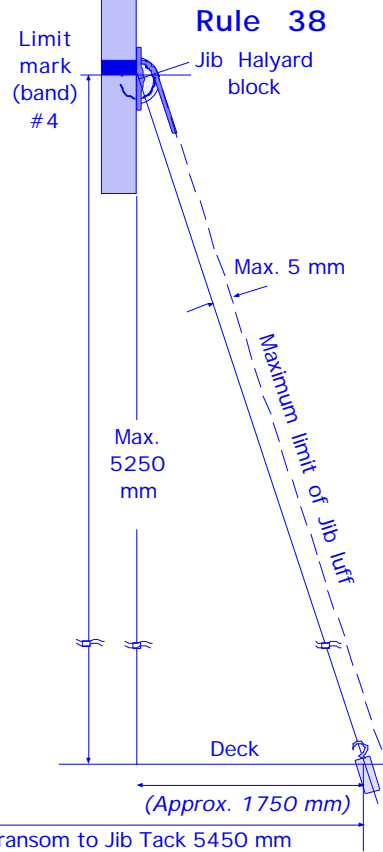

## Boom Rules 65-66, 70

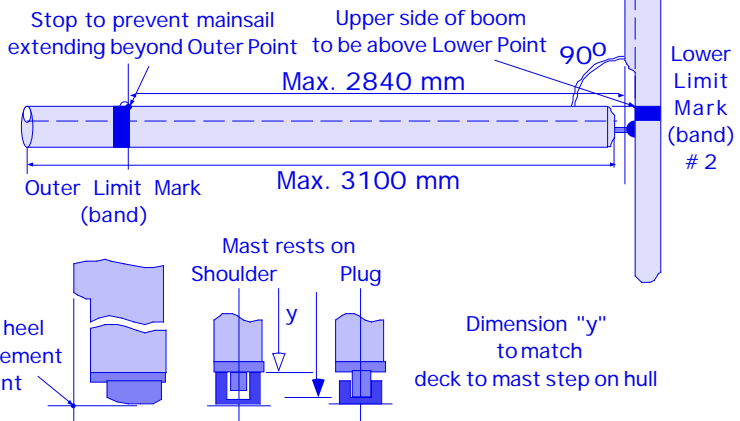

## Jib/Genoa Rules 37-38

Note: The Jib/Genoa is not measured, but must fit within the dimensions specified on the hull and mast

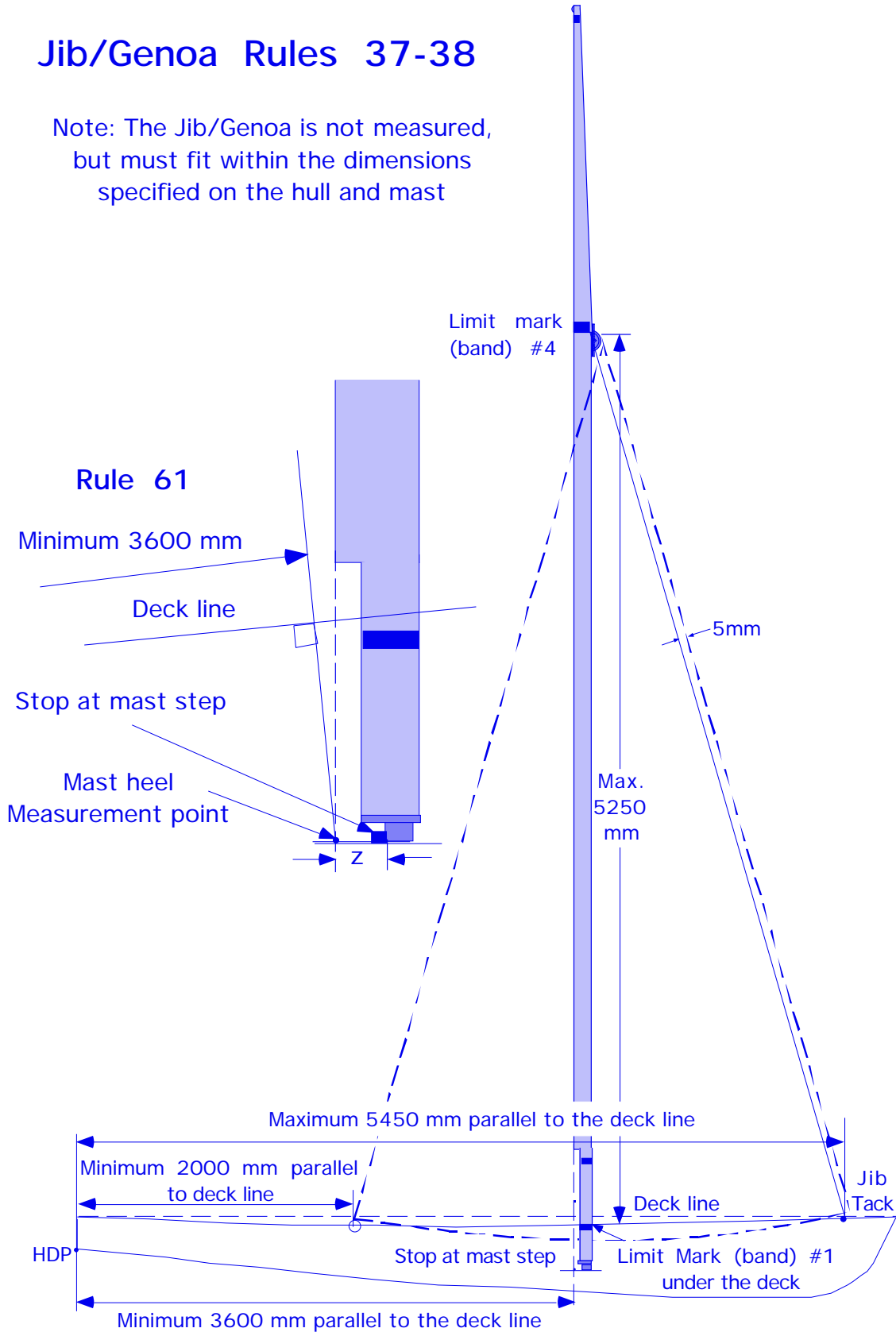

## Mainsail Rules 95 and 99

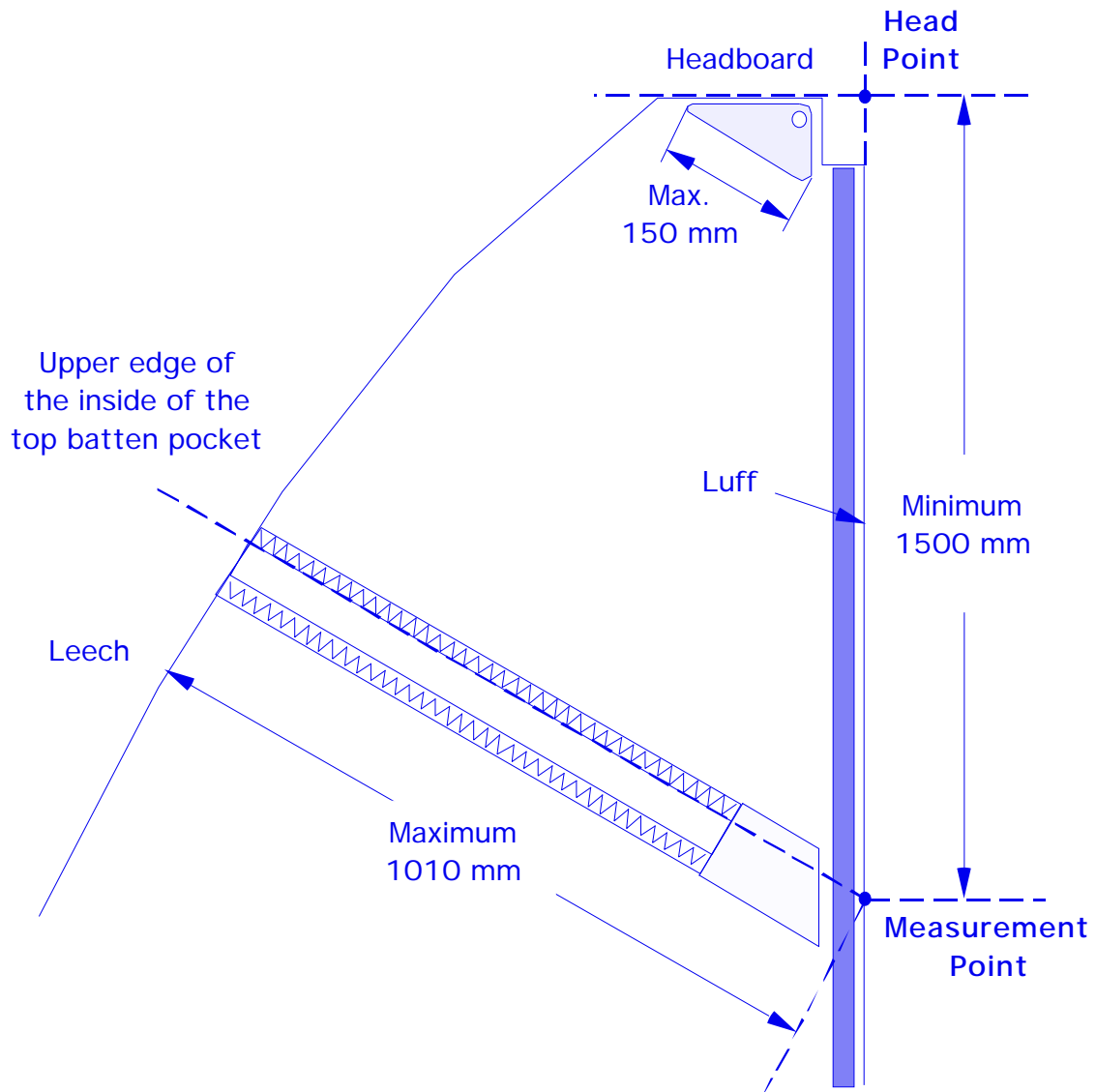

# Mainsail Rules 96-100

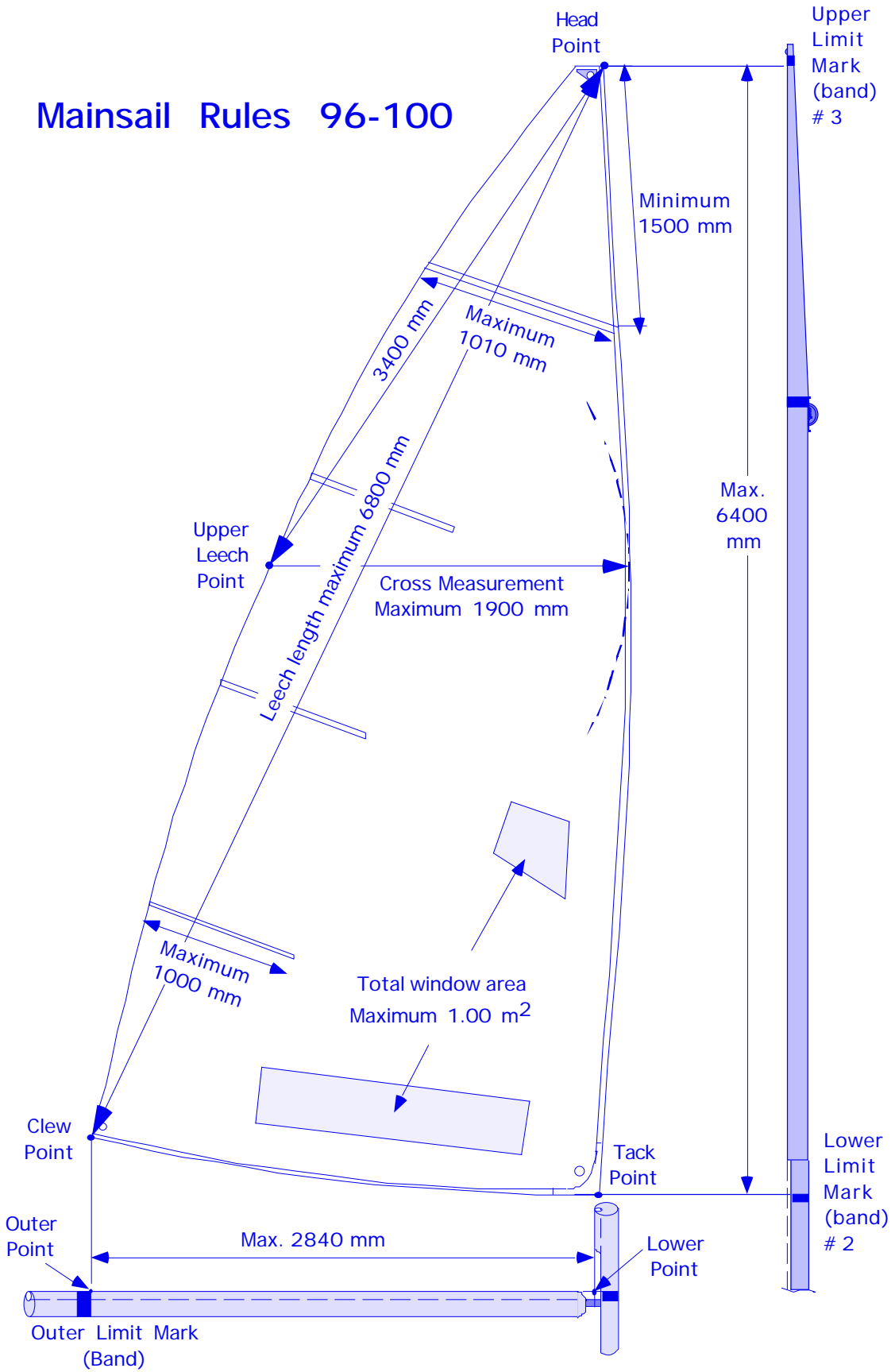

# Spinnaker Rules 102-108

Rule 102 Spinnaker must be symmetrical in form and construction

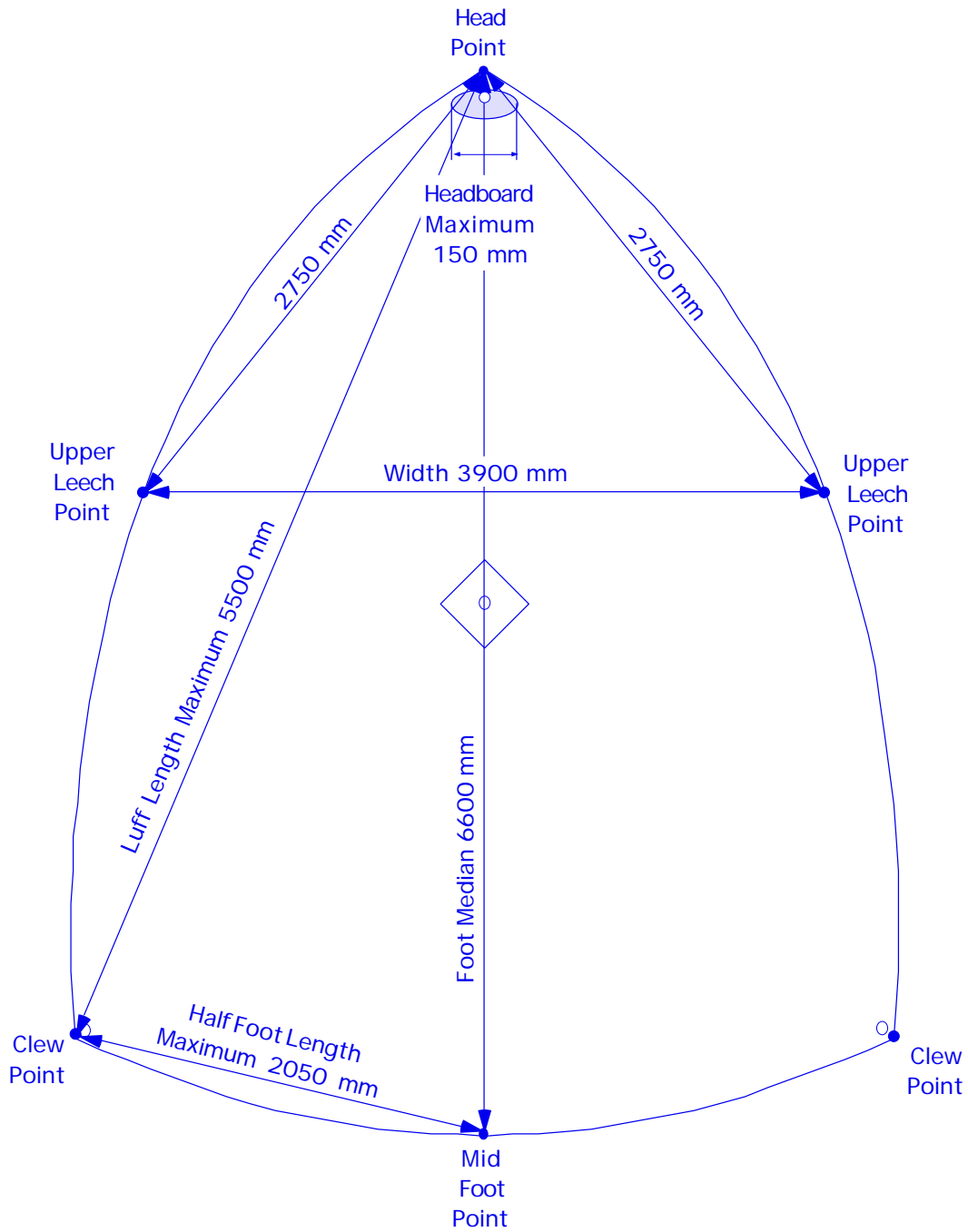

# Advertising, Rule 119

Allowed as per:

ISAF RR 79, Appendix 1, 20.4.4,

Category C

restricted as shown below

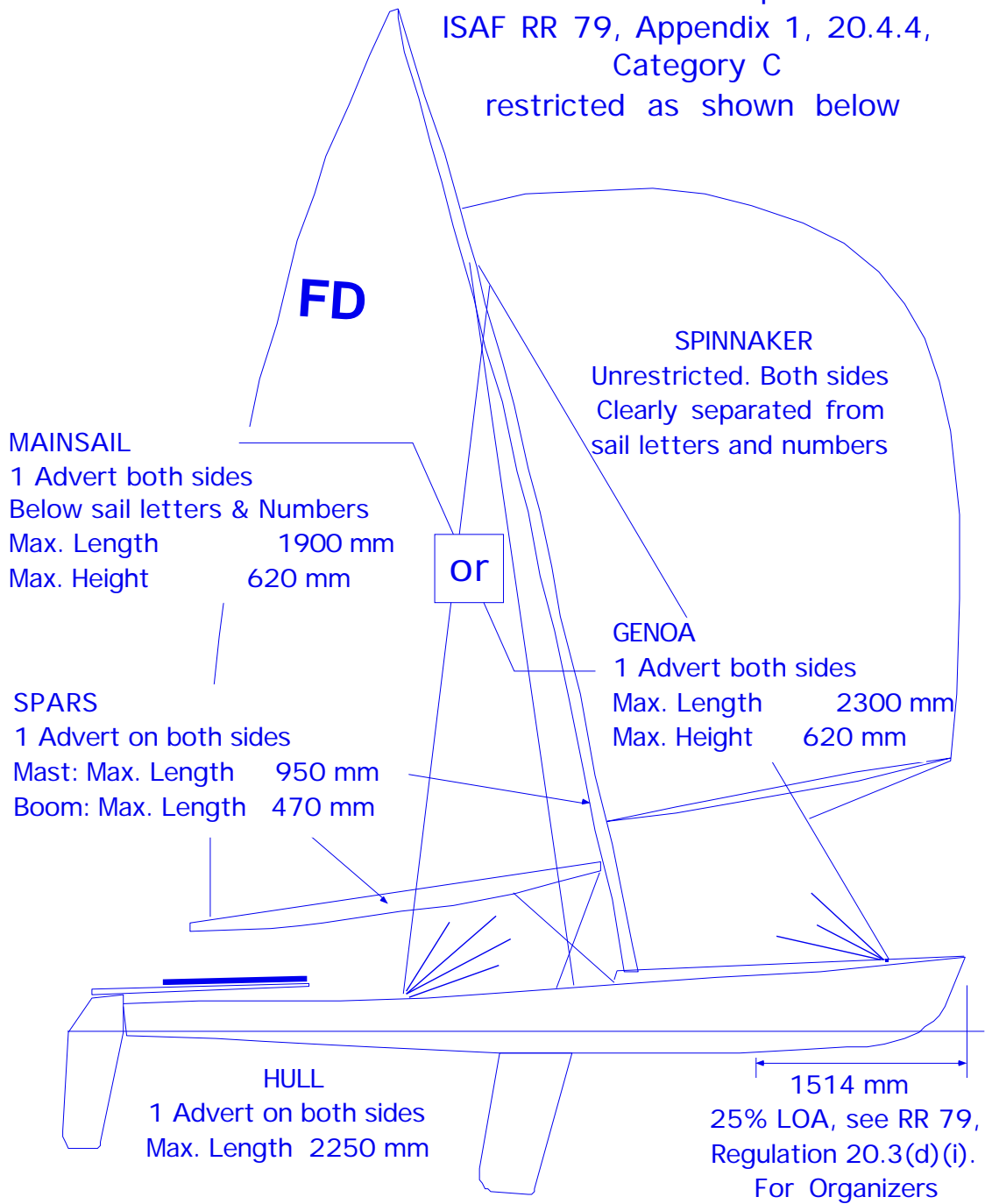

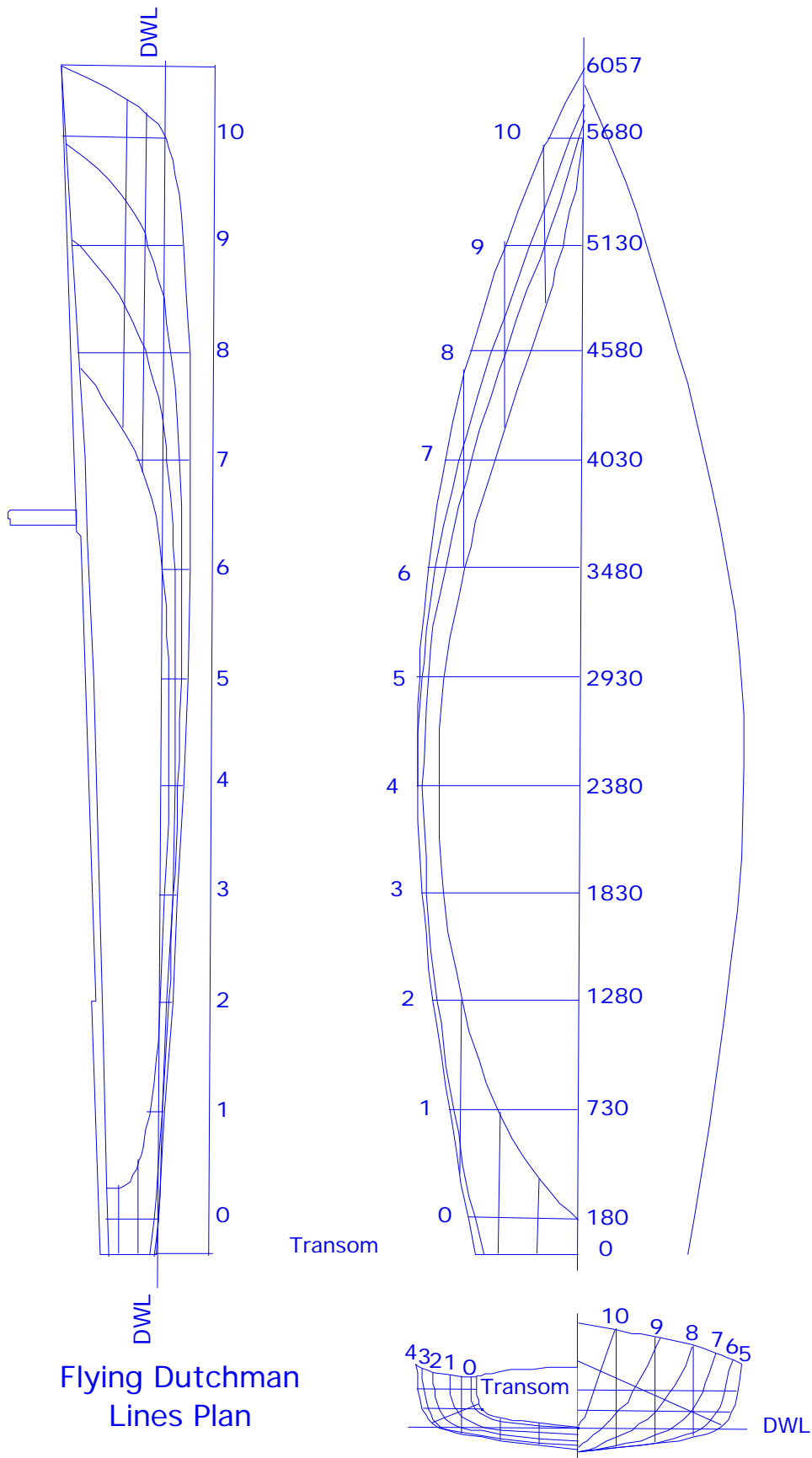

Flying Dutchman  
Lines Plan

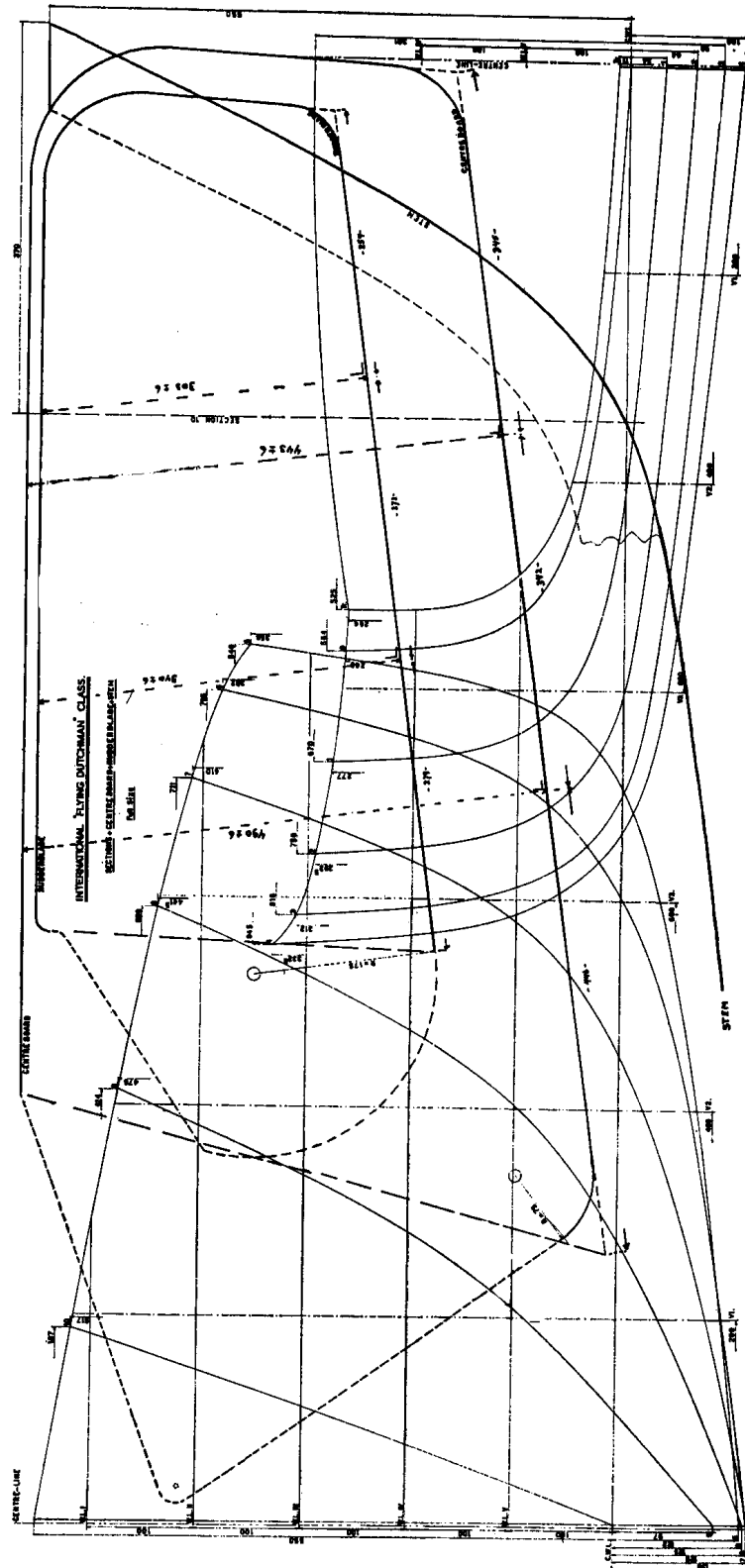

Flying Dutchman Plan (available full size on Mylar)



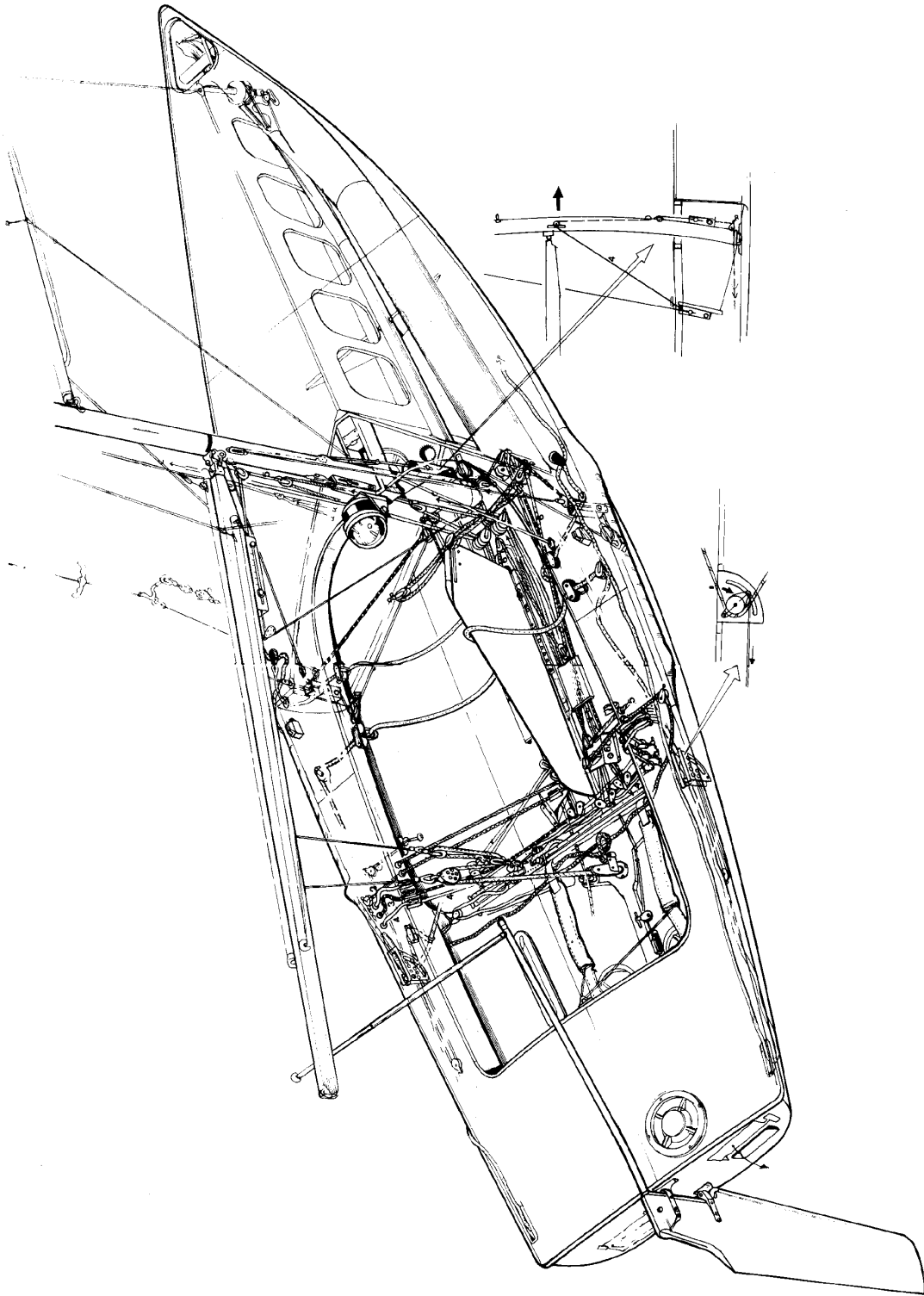

The Diesch 1980 Mader Flying Dutchman

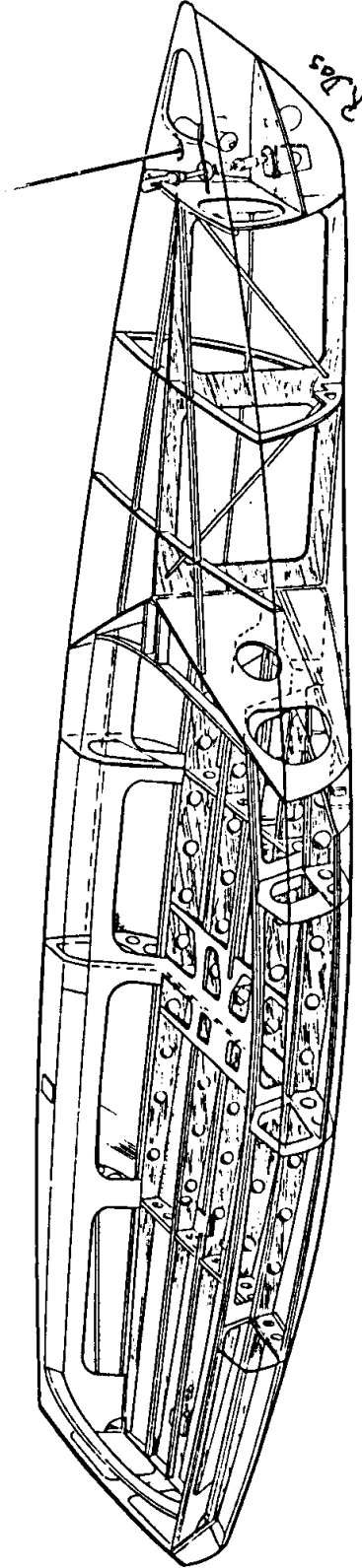

The plan gives a recommended form of reinforced wooden construction, together with suggested scantlings.

FD Table of Offsets in mm

	tr	0	1	2	3	4	5	6	7	8	9	10	waterlines	stem behind	
Half Breadth to outside planking	Posn.fwd.	0	730	1280	1830	2380	2930	3480	4030	4580	5130	5680	6057		
	1										402.5	181.5	1	ord. 11	
	1.5											164.5	1.5	23	
	2								707.5	570.5	380	148	2	45.5	
	2.5											130.5	2.5	69	
	3							839	788	691	548	357.5	2.5	93	
	3.5	525	563.5	669	755	815.5	843	831.5	777.5	674	525	333	3	3	118
	4	524	560	665.5	751	812.5	839.5	824.5	765	655.5	500.5	308.5	3.5	3.5	145
	4.5	515	552	659	745	808.5	835	817	751.5	635	473	280	4	4	174
	5	487	528	641	729	788	814	793	712.5	611	442	247.5	60	4.5	207
	5.5	390.5	446.5	594	691.5	760	787	767.5	672.5	530	349.5	163	22	5	245
	6		3	407.5	603	700	735.5	707	603	451	274.5	111	3	5.5	294
	6.5				187.5	424	548	545.5	472	326	176.5	56		cwl	370
sheer	525	564	670	758	816	845	840	795	711	589	414	187	sheer	370+183	
from cwl to outside planking	0.5	16	5.5	-27.5	-57	-81	-111	-115.5	-108.5	-84.5	-10.5	262	0.5	0	
	1	23.5	12.5	-20.5	-49	-72.5	-100	-101.5	-85.5	-39	90.5		1		
	1.5	34.5	22.5	-11.5	-40	-62.5	-89	-86	-58	15	234		1.5		
	2	52.5	38.5	-1	-30	-52.5	-75	-68	-23	96.5	444		2		
	2.5	115.5	75.5	14.5	-18	-41	-56	-59	28	249			2.5		
	3			54	-1	-27	-42.5	-37	-1.5	131.5			3		
	3.5				58	0	-18	-3.5	376				3.5		
	keel	11	0	-34	-64	-90	-109	-122	-129	-130	-125	-97	0	keel	
	sheer	264	266	277	292.5	312	332.5	356	382	410	441.5	476	517	sheer	
	Posn.fwd.	0	180	730	1280	1830	2380	2930	3480	4030	4580	5130	5680	6057	